



235 2nd Avenue NE
Hickory, NC 28604

October 1st, 2019

Attention HSM Customer:

HSM Transportation & Specialty Manufacturing Company (“HSM”) has reviewed reports of school bus seat foam separation occurring at the adhesive seam along the seat back. HSM will continue addressing these occurrences through the normal warranty process.

HSM has also developed an alternative solution to complete seat back foam replacement.

A Voluntary Technical Service Bulletin and related parts are being made available for order now at no cost. The repair kit is available as #KIT-118 and a single kit includes enough materials to repair (4) seats. HSM will cover shipping and handling costs and ship directly to a customer’s indicated address. We ask that any claimed chargebacks from Dealerships and Distributors be submitted directly to HSM Quality. Installation labor to perform these repairs is defined at 15.5 minutes per seat, following documented instruction INS-196, at a labor rate of \$45 an hour.

HSM has determined all school bus seats utilizing HSM foam inside the seat back and manufactured from January 2017 to August 2019 may require attention.

If there is a performance question, please contact HSM or your original equipment manufacturer.

Sincerely,
Christopher L. Murphy
Director of Quality Assurance
E: clmurphy@hsm solutions.com
P: 479-646-6161 ext 348

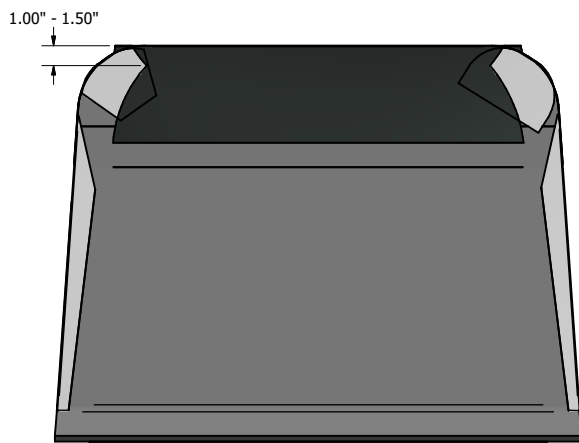

FRONT VIEW

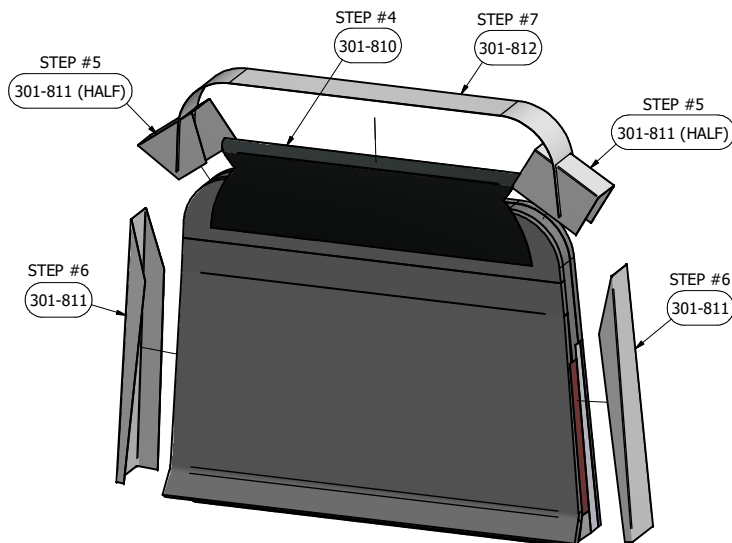

FRONT VIEW
(EXPLODED SCRIM VIEW)

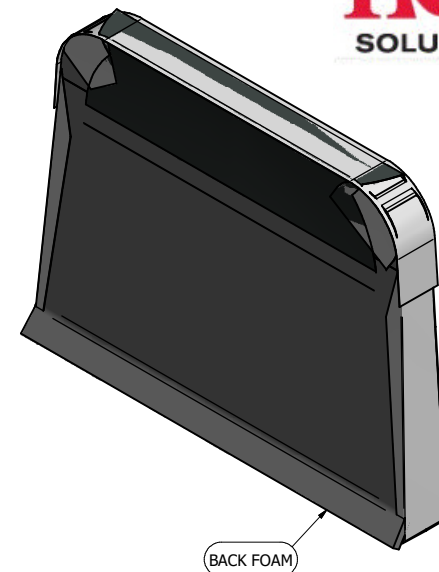

BACK FOAM

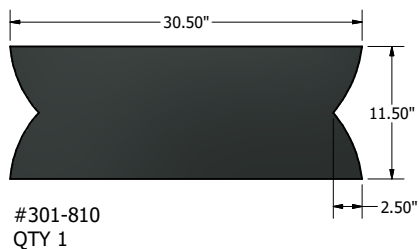

#301-810
QTY 1



#800-696

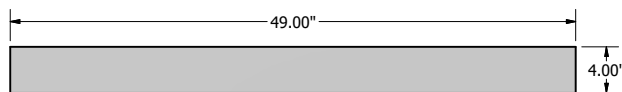

#301-812
QTY 1

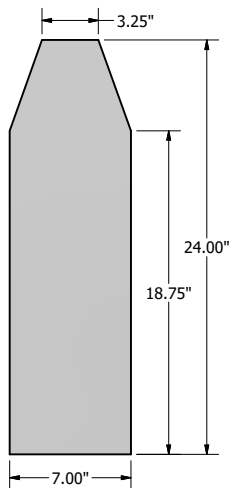

#301-811
QTY 3, ONE PIECE NEEDS
CUT THROUGH MIDDLE
LENGTH WISE

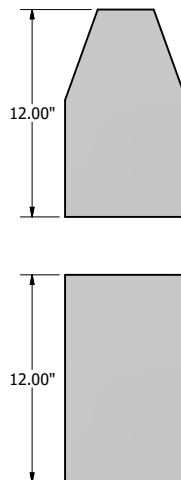

#301-811
TWO HALVES (1 OF 3 QTY)

NOTES:

- SEE PAGE 2 FOR STEP BY STEP INSTRUCTIONS
- PARTS LIST SHOWS QUANTITIES OF PARTS NEEDED FOR ONE SEAT

ITEM	PART NUMBER	QTY	DESCRIPTION
1.4	800-696	.25 CAN	GLUE, SPRAY FAST TACK 85
1.3	301-812	1	SCRIM, (WHITE) 4.00" x 49.00"
1.2	301-811	3	SCRIM, (WHITE) 7.00" X 24.00"
1.1	301-810	1	SCRIM, (BLACK) 11.50" x 30.50"
1	KIT-118	1/4	KIT, SCRIM FOAM SEPERATION FIX

PARTS LIST

THIS DOCUMENT IS CONTROLLED ONLY WHEN VIEWED ONLINE

HSM SOLUTIONS COMPANY. ANY USE OR COPY OF THE DATA CONTAINED ON THIS DRAWING, PHYSICAL OR ELECTRONIC, WITHOUT THE EXPRESSED WRITTEN PERMISSION FROM THE HSM SOLUTIONS CO. IS PROHIBITED.

HSM Corporate
235 2nd Ave NW
Hickory, NC 28601
hsmtransportations.com

PART NUMBER		DESCRIPTION	
INS-196		INSTRUCTION, FOAM SEPERATION FIX	
DRAWN BY atnims	DATE 6/6/2019		
CHECKED BY	DATE		
THIRD ANGLE		TOLERANCES UNLESS OTHERWISE SPECIFIED	
		HOLE DIAMETER	
		SOFT GOODS	
		SEAT ASSEMBLIES	
		WEIGHT: 4.95lbs	
		SHEET SIZE: C	
		SHEET 1 OF 2	
		REV: D	

REV	DATE	DESCRIPTION	FROM	ECN
D	7/25/2019	PARTS LIST KIT QTY NOW 1/4 INSTEAD OF 1; NOTE ADDED ABOUT PART QUANTITIES LISTED ARE FOR ONE SEAT	ALN	CM0930
C	7/18/2019	ADDED ADDITIONAL INSTRUCTIONS & DISCLAIMER ON PAGE 2	TAR	CM0924
B	6/26/2019	PARTS LIST REFERENCES KIT-118 & ADDED NOTE BELOW STEP #3	ALN	CM0903
A	6/13/2019	NEW RELEASE	ALN	CM0893

~ REVISION HISTORY ~

INSTRUCTIONS:

- THIS REPAIR KIT IS DESIGNATED FOR SCHOOL BUS SEATING ONLY.
- THIS REPAIR KIT IS MODULAR AND WORKS ACROSS THE "SEAM" MOLDING LINE OF SEAT BACK FOAM AND IS NOT APPROVED FOR ANY OTHER AREA.
- THIS REPAIR IS DESIGNATED ONLY FOR RECYCLED REBOND FOAM. IT SHOULD NEVER BE USED FOR PRIME FOAM APPLICATIONS
- AMBIENT TEMPERATURE FOR INSTALLATION SHALL NOT EXCEED 120F.
- ANY INSTALLATION OUTSIDE OF THE APPLICATION OR OTHERWISE AS DESIGNATED HEREIN IS INCORRECT AND AT END USERS OWN RISK.
- CONSISTENT PERFORMANCE INSPECTIONS ARE REQUIRED AFTER ANY REPAIR.
- THERE IS NO WARRANTY OR RETURN FOR THIS REPAIR KIT. THIS REPAIR KIT IS PROVIDED "AS IS" "WHERE IS" AND WITHOUT ANY WARRANTY, WHETHER IMPLIED OR AT LAW. NO EXCEPTIONS.

STEP BY STEP:

1. IDENTIFY SEATS IN NEED OF FOAM FIX.
2. ASSURE ALL SCRIM PARTS AND GLUE ARE AVAILABLE FROM KIT-118. CUT ONE PART #301-811 INTO TWO PIECES IN HALF FROM TOP TO BOTTOM. (SEE VIEW 301-811 TWO HALVES)

NOTE! TO EFFECTIVELY USE GLUE, APPLY LIGHT COMPLETE COVERAGE TO SCRIM AND FOAM.

3. REMOVE BACK COVER OF SEAT BY STARTING AT BOTTOM AND UN-ATTACHING BACK COVER. FROM BOTTOM UP, ROLL COVER CAREFULLY ON ALL SIDES ABOUT HALFWAY UP AND PULL UPWARD TO REMOVE COVER COMPLETELY.

NOTE! ASSURE SCRIM PARTS ARE SMOOTHED OUT AS MUCH AS POSSIBLE WHILE APPLYING AND TAKE EXTRA CARE ON ADHERING CORNERS. IF ANY SCRIM COVERS BELT OPENINGS, CUT SCRIM MATCHING FOAM CUTOUT.

4. START WITH SCRIM PART #301-810. ADHERE TO FOAM TOP, FRONT AND BACK. OFFSET TOWARD FRONT 1.00" - 1.50" AS SHOWN IN FRONT VIEW.

5. APPLY 2 HALF SCRIM PARTS #301-811 TO FOAM SIDES CENTERED OVER RADIUSSES.

6. APPLY 2 SCRIM PARTS #301-811 TO EACH SIDE OF FOAM. LOCATE SCRIM FLUSH TO BOTTOM, CENTER VERTICALLY AND WRAP REMAINING TO FRONT AND BACK OF FOAM.



7. LAST REMAINING SCRIM PART #301-812 APPLY TO TOP OF FOAM CENTER HORIZONTALLY, WRAP ANY EXCESS TO FRONT AND BACK OF FOAM.

8. REINSTALL COVER BY PUTTING COVER OVER TOP OF FOAM. CAREFULLY PULL COVER BACK DOWNWARD ON ALL SIDES. SECURE COVER BOTTOM AS WAS BEFORE REMOVAL.

NOTE! ASSURE BACK FOAM CAVITY IS AGAINST FRAME TUBING AND COVER IS PULLED SNUG IN ALL LOCATIONS.

DISCLAIMER OF WARRANTIES

NO EXPRESS OR IMPLIED WARRANTIES OF ANY TYPE, WHETHER OF MERCHANTABILITY, FITNESS FOR A PARTICULAR PURPOSE, COMPLIANCE WITH SAFETY STANDARDS, RESISTANCE TO FLAMMABILITY, AND/OR OTHERS ARISING FROM COURSE OF DEALING OR TRADE, OR OTHERWISE SHALL APPLY TO THESE GOODS OR PRODUCTS. HSM EXPRESSLY DISCLAIMS ALL WARRANTIES, EXPRESS, IMPLIED OR STATUTORY INCLUDING WITHOUT LIMITATION ANY IMPLIED WARRANTY OF MERCHANTABILITY, FITNESS FOR A PARTICULAR PURPOSE, NONINFRINGEMENT, OR ARISING FROM COURSE OF PERFORMANCE, DEALING, USAGE OR TRADE. WITHOUT LIMITING THE GENERALITY OF THE FOREGOING, HSM MAKES NO CLAIM, REPRESENTATION, OR WARRANTY OF ANY KIND AS TO THE UTILITY OF THE GOODS OR PRODUCTS FOR CUSTOMER'S INTENDED USES. THESE GOODS AND PRODUCTS PROVIDED HEREUNDER ARE PROVIDED ON AN "AS IS" "WHERE IS" BASIS.

		<small>THIS DOCUMENT IS CONTROLLED ONLY WHEN VIEWED ONLINE</small> <small>THIS DRAWING AND THE CONTENTS ARE THE PROPERTY OF THE HSM SOLUTIONS COMPANY. ANY USE OR COPY OF THE DATA CONTAINED ON THIS DRAWING, PHYSICAL OR ELECTRONIC, WITHOUT THE EXPRESSED WRITTEN PERMISSION FROM THE HSM SOLUTIONS CO. IS PROHIBITED.</small>		<small>HSM Corporate</small> <small>235 2nd Ave NW</small> <small>Hickory, NC 28601</small> <small>hsmtransportations.com</small>	
<small>PART NUMBER</small> INS-196		<small>DESCRIPTION</small> INSTRUCTION, FOAM SEPARATION FIX			
<small>DRAWN BY</small> alnim	<small>DATE</small> 5/6/2019				
<small>CHECKED BY</small> 	<small>DATE</small> 				
<small>THIRD ANGLE</small> 		<small>TOLERANCES UNLESS OTHERWISE SPECIFIED</small>			<small>WEIGHT: 4.95lbs</small>
		<small>.X = ± .1</small> <small>.XX = ± .03</small> <small>.XXX = ± .005</small> <small>ANGLES ± 2°</small>	<small>HOLE DIAMETER</small> <small>0-.500 + .010</small> <small>-.005</small> <small>.501+ +.012</small> <small>-.006</small>	<small>SOFT GOODS</small> <small>± .12</small> <small>SEAT ASSEMBLIES</small> <small>± .38</small>	<small>SHEET SIZE: C</small> <small>SHEET 2 OF 2</small> <small>REV: D</small>

\\CEW-CAD\SVR\Engineering\CAD\Inventor\CAD Files\Drawings\KIT Field Assy Kits\KIT-118.dwg

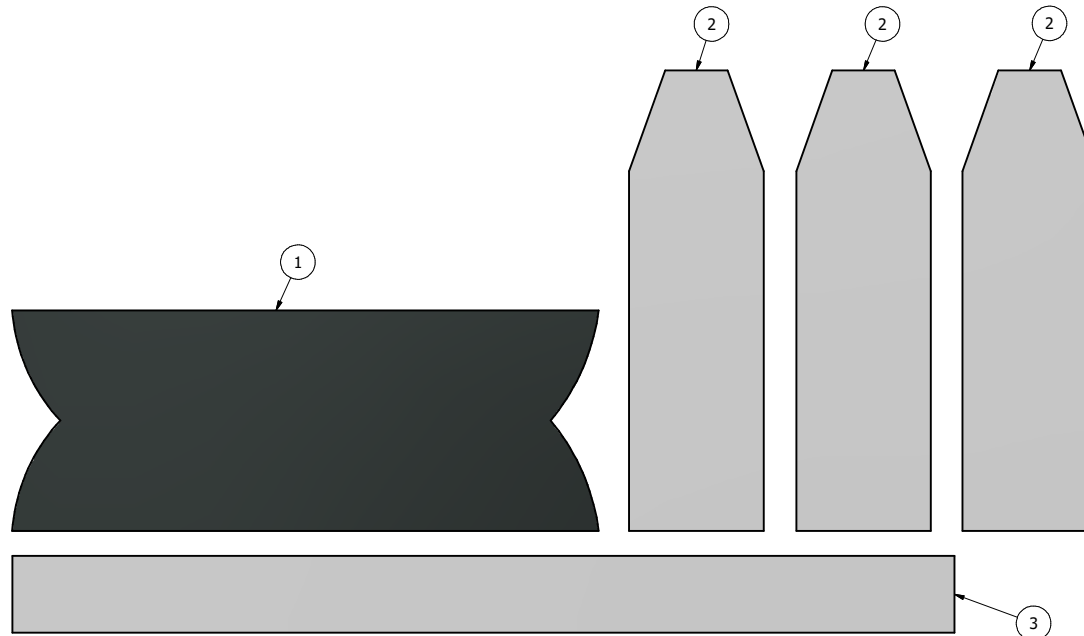

REFERENCE INS-196 FOR FOAM SEPARATION FIX

4	800-696	1 CAN	GLUE, SPRAY FAST TACK 85
3	301-812	4	SCRIM, (WHITE) 4.00" x 49.00"
2	301-811	12	SCRIM, (WHITE) 7.00" X 24.00"
1	301-810	4	SCRIM, (BLACK) 11.50" x 30.50"
ITEM	PART NUMBER	QTY	DESCRIPTION

PARTS LIST

THIS DOCUMENT IS CONTROLLED ONLY WHEN VIEWED ONLINE



THIS DRAWING AND THE CONTENTS ARE THE PROPERTY OF THE HSM SOLUTIONS COMPANY. ANY USE OR COPY OF THE DATA CONTAINED ON THIS DRAWING, PHYSICAL OR ELECTRONIC, WITHOUT THE EXPRESSED WRITTEN PERMISSION FROM THE HSM SOLUTIONS CO. IS PROHIBITED.

HSM Corporate
235 2nd Ave NW
Hickory, NC 28601
hsmtransportation.com

PART NUMBER KIT-118		DESCRIPTION KIT, SCRIM FOAM SEPARATION FIX	
DRAWN BY alnims	DATE 6/27/2019		
CHECKED BY	DATE		
THIRD ANGLE		TOLERANCES UNLESS OTHERWISE SPECIFIED	
		.X = ± .1	HOLE DIAMETER
		.XX = ± .03	SOFT GOODS ± .12
		.XXX = ± .005	SEAT ASSEMBLIES ± .38
		ANGLES ± 2°	
		WEIGHT: 0.01lbs	SHEET SIZE: C
			SHEET 1 OF 1
			REV: B

B	7/25/2019	PARTS LIST NOW SHOWS QTYs FOR 4 SEATS WAS 1 SEAT	ALN	CM0930
A	6/27/2019	NEW RELEASE	ALN	CM0903
REV	DATE	DESCRIPTION	FROM	ECN
^ REVISION HISTORY ^				

SERVICE BULLETIN KIT ORDER CARD

S19AK

CUSTOMER NAME: _____

SHIPPING ADDRESS: _____

CITY: _____ STATE: _____ ZIP CODE: _____

BLUE BIRD BODY NUMBER REQUIRED FOR ALL PARTS SHIPMENTS: _____
(PLEASE ATTACH A LIST AS NECESSARY)

ORDER DATE: ____/____/____.

PLEASE SPECIFY THE ORDER QUANTITY OF THE FOLLOWING PARTS:

KIT-118 (Each Kit fixes 4 seats) QTY. _____ EA.

Contact: Gina Moore glmoore@hsm solutions.com 478-542-3888

SIGNATURE: _____ DATE: _____

SERVICE BULLETIN KIT ORDER CARD

S19AK

CUSTOMER NAME: _____

SHIPPING ADDRESS: _____

CITY: _____ STATE: _____ ZIP CODE: _____

BLUE BIRD BODY NUMBER REQUIRED FOR ALL PARTS SHIPMENTS: _____
(PLEASE ATTACH A LIST AS NECESSARY)

ORDER DATE: ____/____/____.

PLEASE SPECIFY THE ORDER QUANTITY OF THE FOLLOWING PARTS:

KIT-118 (Each Kit fixes 4 seats) QTY. _____ EA.

Contact: Gina Moore glmoore@hsm solutions.com 478-542-3888

SIGNATURE: _____ DATE: _____



256 Industrial Blvd.
Fort Valley, GA. 31030

ATTENTION: CUSTOMER SERVICE DEPT.



256 Industrial Blvd.
Fort Valley, GA. 31030

ATTENTION: CUSTOMER SERVICE DEPT.

SERVICE BULLETIN RESPONSE CARD S19AK

CUSTOMER NAME: _____

BLUE BIRD BODY NUMBER: _____

SERVICE COMPLETED BY: _____

COMPLETION DATE: _____ / _____ / _____ .

PLEASE SELECT ONE OF THE FOLLOWING:

_____ VEHICLE IS NO LONGER IN SERVICE – DECLINES SERVICE

_____ VEHICLE NO LONGER REGISTERED TO THIS OWNER

_____ SERVICE REMEDY HAS BEEN COMPLETED

SIGNATURE: _____ DATE: _____

SERVICE BULLETIN RESPONSE CARD S19AK

CUSTOMER NAME: _____

BLUE BIRD BODY NUMBER: _____

SERVICE COMPLETED BY: _____

COMPLETION DATE: _____ / _____ / _____ .

PLEASE SELECT ONE OF THE FOLLOWING:

_____ VEHICLE IS NO LONGER IN SERVICE – DECLINES SERVICE

_____ VEHICLE NO LONGER REGISTERED TO THIS OWNER

_____ SERVICE REMEDY HAS BEEN COMPLETED

SIGNATURE: _____ DATE: _____

SERVICE BULLETIN RESPONSE CARD S19AK

CUSTOMER NAME: _____

BLUE BIRD BODY NUMBER: _____

SERVICE COMPLETED BY: _____

COMPLETION DATE: _____ / _____ / _____ .

PLEASE SELECT ONE OF THE FOLLOWING:

_____ VEHICLE IS NO LONGER IN SERVICE – DECLINES SERVICE

_____ VEHICLE NO LONGER REGISTERED TO THIS OWNER

_____ SERVICE REMEDY HAS BEEN COMPLETED

SIGNATURE: _____ DATE: _____

SERVICE BULLETIN RESPONSE CARD S19AK

CUSTOMER NAME: _____

BLUE BIRD BODY NUMBER: _____

SERVICE COMPLETED BY: _____

COMPLETION DATE: _____ / _____ / _____ .

PLEASE SELECT ONE OF THE FOLLOWING:

_____ VEHICLE IS NO LONGER IN SERVICE – DECLINES SERVICE

_____ VEHICLE NO LONGER REGISTERED TO THIS OWNER

_____ SERVICE REMEDY HAS BEEN COMPLETED

SIGNATURE: _____ DATE: _____

HSM

TRANSPORTATION SOLUTIONS

256 Industrial Blvd.
Fort Valley, GA. 31030

ATTENTION: CUSTOMER SERVICE DEPT.

HSM

TRANSPORTATION SOLUTIONS

256 Industrial Blvd.
Fort Valley, GA. 31030

ATTENTION: CUSTOMER SERVICE DEPT.

HSM

TRANSPORTATION SOLUTIONS

256 Industrial Blvd.
Fort Valley, GA. 31030

ATTENTION: CUSTOMER SERVICE DEPT.

HSM

TRANSPORTATION SOLUTIONS

256 Industrial Blvd.
Fort Valley, GA. 31030

ATTENTION: CUSTOMER SERVICE DEPT.